

**NOTICE: This document is a TAPPI Standard in ballot. Although available for public viewing, it is still under TAPPI's copyright and may not be reproduced or distributed without permission of TAPPI. This document is current under review to be maintained as a TAPPI Standard.**

WI 240808.01

T 441

BALLOT NO. 02 - SARG

DRAFT NO. 02

DATE October 22, 2024

WORKING GROUP  
CHAIR Ben Frank

SUBJECT  
CATEGORY Physical Properties

RELATED  
METHODS See "Additional Information"

**CAUTION:**

This Test Method may include safety precautions which are believed to be appropriate at the time of publication of the method. The intent of these is to alert the user of the method to safety issues related to such use. The user is responsible for determining that the safety precautions are complete and are appropriate to their use of the method, and for ensuring that suitable safety practices have not changed since publication of the method. This method may require the use, disposal, or both, of chemicals which may present serious health hazards to humans. Procedures for the handling of such substances are set forth on Safety Data Sheets which must be developed by all manufacturers and importers of potentially hazardous chemicals and maintained by all distributors of potentially hazardous chemicals. Prior to the use of this method, the user must determine whether any of the chemicals to be used or disposed of are potentially hazardous and, if so, must follow strictly the procedures specified by both the manufacturer, as well as local, state, and federal authorities for safe use and disposal of these chemicals.

## **Water Absorptiveness of Sized (Non-Bibulous) Paper, Paperboard, and Corrugated Fiberboard (Cobb Test)** ***(Five-year review of Official Method T 441 om-20)*** ***(Changes from Draft 1 shown through strikethroughs/underlines)***

### **1. Scope**

1.1 This method describes a procedure for determining the quantity of water absorbed by nonbibulous paper, paperboard, and corrugated fiberboard in a specified time under standardized conditions. It is based on studies by Cobb and Lowe (1), Cobb (2) and other investigators (3, 4).

1.2 For testing unsized and absorbent paper or paperboard, see TAPPI T 432 "Water Absorbency of Bibulous Papers."

### **2. Significance**

2.1 Water absorptiveness is a function of various characteristics of paper or board such as sizing, porosity, etc. This method is generally applicable to sized paper, paperboard and corrugated fiberboard, but it is not recommended as a sizing test for writing paper.

### 3. Definitions

3.1 *Water absorptiveness (Cobb value)*, the mass of water absorbed in a specific time by 1 square meter (10.76 square feet) of paper, paperboard, or corrugated fiberboard under 1 cm of water.

### 4. Apparatus

4.1 *Water absorption apparatus*<sup>1</sup>, a device that permits one side of the specimen to be wetted uniformly at the moment the soaking period begins, and to allow controlled rapid removal of the water from the specimen at the end of the test period. The specimen holder as shown in Fig. 1 comprises a metal ring with a machined lower face,  $11.28 \pm 0.02$  cm (4.44 in.) inside diameter (corresponding to a cross-sectional area of  $100 \text{ cm}^2$  (15.5 in.<sup>2</sup>)), 2.5 cm (1 in.) high and about 0.6 cm (0.24 in.) thick, clamped to a flat base plate of the same or bigger size. On the base plate is a rubber mat, larger than the outside dimensions of the ring, on which the specimen is clamped.

**NOTE 1:** The metal parts should preferably be a brass or other corrosion-resistant material.

**NOTE 2:** Several versions of the water absorption apparatus are now available. Some use different ring sizes that fit in the same clamping fixture and some use different clamping methods. A change in clamping method may affect the speed at which the sample can be removed from the apparatus. It has been reported that spring loaded clamps may reduce leakage when testing corrugated fiberboard.

4.1.1 A soft elastic non-absorbent gasket may be utilized between the ring and specimen to prevent leakage. The gasket should have the same internal dimensions as the ring.

4.2 *Metal roller*, solid brass, stainless steel or other corrosion-resistant material, having a smooth face 20 cm wide and weighing  $10.0 \pm 0.5$  kg (22  $\pm$  1.1 lb).

4.3 *Timer*, stopwatch or electric timer reading in seconds.

4.4 *Graduated cylinder*, 100 mL.

4.5 *Balance*, with an accuracy of 0.01 g, or better.

---

<sup>1</sup>Names of suppliers of testing equipment and materials for this method may be found on the Test Equipment Suppliers list, available as part of the CD or printed set of Standards, or on the TAPPI website general Standards page.

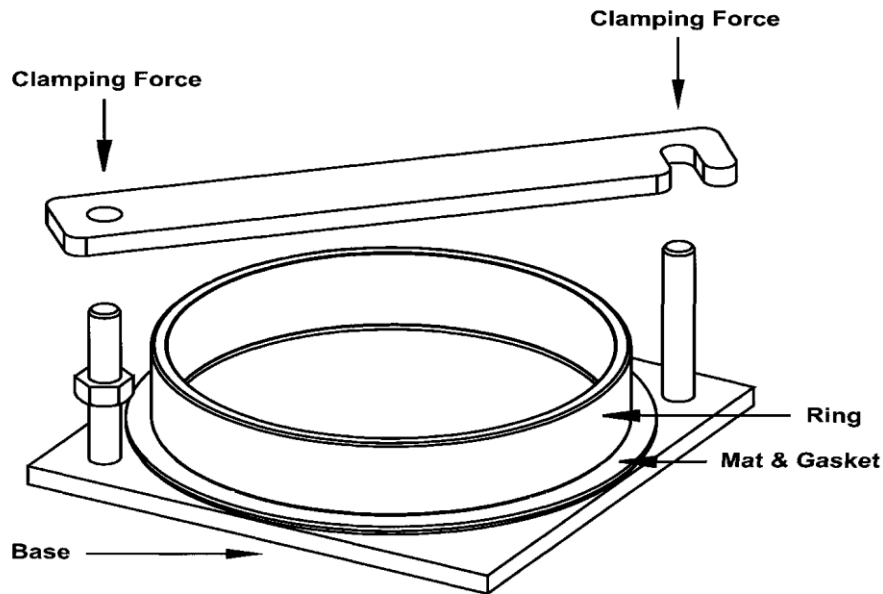

Fig. 1. Specimen holder.

## 5. Materials

5.1 *Blotting paper*<sup>1</sup>, sheets of standard blotting paper, 200 mm square, weighing  $250 \pm 10 \text{ g/m}^2$  (AD) in accordance with TAPPI T 410, a thickness of 0.508 to 0.635 mm in accordance with TAPPI T 411, and having a minimum rate of absorbency of 25 s/1.0 mL of water when tested in accordance with TAPPI T 432 "Water Absorbency of Bibulous Papers." The wet expansion shall not exceed 2.5% in the cross direction following the specification of TAPPI T 205. The blotters shall be white, produced from fully bleached chemical pulp free of any additives. They shall be flat, uniform, and free of wrinkles and dirt.

5.1.1 Blotting paper should not be used for more than one test, as the absorptive nature of the material changes once it has been exposed to water during the first use.

5.2 *Water*, distilled (pure) or deionized.

## 6. Sampling and test specimens

6.1 Obtain a sample of the material to be evaluated in accordance with TAPPI T 400 "Sampling and Accepting a Single Lot of Paper, Paperboard, Containerboard, or Related Product." From each test unit, cut specimens to a size slightly greater than the outside dimensions of the ring of the apparatus, i.e., squares 12.5 × 12.5 cm (4.9 × 4.9 in.). The specimens should be free from folds, wrinkles, or other blemishes not commonly inherent in the paper.

6.1.1 For corrugated fiberboard, specimens should additionally be free of scores, perforations, tears, and other modifications that would prevent a flat, continuous testing surface. Printing may be included in test area with no statistical impact on Cobb value. (See 11.6.)

6.1.2 The standard test area is 100 cm<sup>2</sup>. If the available specimens are too small, a proportionately smaller test area may be used providing that the volume of water is reduced to provide a pressure head of 1 ± 0.1 cm. Other common test areas include 25 cm<sup>2</sup> and 10 cm<sup>2</sup>. A change in area from 100 cm<sup>2</sup> should be noted in the report.

6.2 While Cobb absorptivity is often considered a bulk property, some materials may have different absorptive properties from each side (felt or wire). Sample enough material so that complete testing can be performed on one or both sides of the paper to be evaluated. Specimens tested on one side cannot be reused for evaluation of the properties of the other side.

6.2.1 For hard-sized papers (absorbing less than 100 g of water/m<sup>2</sup> (0.22 lb/10.76 ft<sup>2</sup>) in 2 minutes), use 5 specimens per side.

6.2.2 For soft-sized papers (absorbing more than 100 g of water/m<sup>2</sup> (0.22 lb/10.76 ft<sup>2</sup>) in 2 minutes), use 10 specimens per side.

6.2.3 For corrugated fiberboard at least five tests should be carried out on the outside (double back) liner.

6.2.4 United Nations and United States D.O.T. regulations for the shipment of hazardous materials specify a 30-min Cobb test for the outer surface (double back liner) of corrugated board. Five tests are required on the outer surface. When testing for U.N./U.S. D.O.T. compliance for the shipment of hazardous materials the user is advised to refer to specific standards for additional information.

## 7. Procedure

7.1 Precondition and condition the specimens in an atmosphere in accordance with TAPPI T 402 "Standard Conditioning and Testing Atmospheres for Paper, Board, Pulp Handsheets, and Related Products." Test the materials in the conditioning atmosphere.

7.2 Weigh each specimen to the nearest 0.01 g.

7.3 Place a dry rubber mat on the metal plate and lay a weighed specimen on it. After wiping the metal ring dry (do not use heat), place it upon the specimen, and fasten it in place with the crossbar (or other clamping mechanism) to prevent any leakage between the ring and the specimen.

7.3.1 For materials where leakage between the ring and the upper surface of the test specimen may occur during the test, a gasket may be used between the ring and the specimen.

**NOTE 3:** On corrugated fiberboard, some users have overcome leakage by either removing the flutes from the back of a sample or by crushing the flutes prior to testing. The former approach has been shown in round robin studies to impact (reduce) test results and is not recommended. See 11.6.

7.4 Pour 100 mL of water (23 ± 1°C (73.4 ± 1.8°F)) into the ring as rapidly as possible thus giving a head of 1.0 ± 0.1 cm (0.39 in.). Start the stopwatch immediately. At 10 ± 2 s before the expiration of the predetermined test period (usually 120 s for paper or 1800 s for combined board), pour the water quickly from the ring, taking great care not to drip any of the water upon the outside portion of the specimen. Promptly loosen the wing nuts (or other applicable clamping mechanism) and swing the crossbar out of the way while holding the ring in position by pressing it down with one hand. Carefully, but quickly, remove the ring and place the specimen with its wetted side up on a sheet of blotting paper resting on a flat rigid surface.

**NOTE 4:** When different areas are used (25 cm<sup>2</sup> and 10 cm<sup>2</sup> being typical), proportionally less water is used in order to maintain a depth of 1.0 ± 0.1 cm (0.39 in.).

7.4.1 Reject samples that show signs of leakage or spillage around the clamping area.

**Deleted:** If a lot of paper is being tested to determine whether it meets specifications, o

**Deleted:** paper

**Deleted:** 1

**Deleted:** ,

**Deleted:** firmly enough

**Deleted:** soft elastic non-absorbent gasket may be used. The gasket should have the same internal dimensions as the ring

**Deleted:** ,

7.4.2 If any liquid has passed through the sheet to the rubber mat, the test is not acceptable and should be rejected. When this occurs, either shorten the test time or fasten two or more specimen sheets together in an area outside the test area. In such a case, the calculated test area remains that of the inside ring.

7.4.3 The standard test time is a period of 120 s on a single-sheet thickness using 100 mL of water to wet an area 1 cm deep. Such conditions are suitable for most well-sized papers. For combined board, the standard time is typically 1800 s.

7.4.3.1 Testing times may be adjusted according to the water absorptiveness and special natures of the paper or board under consideration and by agreement of the interested parties. In that case, the nonstandard time must be called out explicitly in the report and an explanation provided for why times were adjusted.

7.4.3.2 For times exceeding an hour, the user may want to add a glass cover to minimize evaporation. In all cases, the difference in time between removing excess water and blotting shall be  $10 \pm 2$  s.

7.5 Exactly at the end of the predetermined test period, place a second sheet of blotting paper on top of the specimen and remove the surplus water by moving the hand roller once back and once forward over the covered specimen without exerting any additional pressure on the roller. Specimens with excess water after blotting, as shown by glossy areas on the surface, must be rejected and the test repeated, using a shorter time frame.

7.5.1 On corrugated fiberboard the roller should be applied with its axis parallel to the flutes. In the case of boards coated with a barrier material it is important that a water film does not remain on the surface of the board.

7.5.2 Where corrugated fiberboard is indented by the cylinder edge or which exhibits "washboarding," it may not be possible for the blotting paper to contact the entire wet area of the test piece. In such cases it is recommended that instead of using the roller, the back of the blotting paper is gently rubbed by hand.

7.5.3 For some coated papers, the roller and blotter paper approach may also not remove all the surface water. In this case, gently rubbing the surface of the blotter paper by hand may also serve to remove the surface water and avoid an erroneously high result.

7.6 Fold the specimen with the wetted area inside. Immediately reweigh it to the nearest 0.01 g.

7.6.1 In the case of corrugated fiberboard it may not be possible to fold the test piece. In such cases, the second weighing must be carried out with the least possible delay.

7.7 For the standard test area of 100 cm<sup>2</sup>, subtract the conditioned weight of the specimen from its final weight, and multiply the gain in weight in grams by 100 to obtain the weight of water absorbed in grams per square meter:

$$\text{Weight of water, g/m}^2 = [\text{Final weight, g} - \text{Conditioned weight, g}] \times 100$$

7.7.1 For smaller test areas of 25 cm<sup>2</sup> and 10 cm<sup>2</sup>, the multiplier is 400 and 1000 respectively.

## 8. Report

8.1 Report the absorptiveness, calculated as the average weight of the water absorbed in grams per square meter, for the wire and the felt side of the paper separately. If desired, state also the maximum and minimum values for each side. Include the test duration in the report. Deviations from standard conditions due to shorter times, smaller test specimens, or additional plies shall be included in the report.

## 9. Precision

9.1 The following estimates of repeatability and reproducibility are based on results from two studies.

9.1.1 The estimates for hard-sized printing papers were obtained from a limited study for means of five specimens on the same side in a 120 s Cobb test.

9.1.2 The precision estimates for linerboard and corrugated boxes were obtained from a 2002 study that compared different methods of preparing corrugated board (crushing, separating & testing as-is) and different clamping methods (wing-nut & spring-clamp). (See 11.6.)

Deleted: pad

9.1.2.1 The corrugated box data was obtained from 17 laboratories for two different samples, testing the combined board for 1800 s without crushing or separating the combined board. One sample used a white-top linerboard. The precision estimates are based on 5 determinations per test result and 1 test result per lab, per box.

9.1.2.2 The linerboard data was obtained from 14 laboratories for two different samples. The linerboard samples used were from the same rolls used to construct the boxes in the study; one linerboard sample was natural kraft and the other a white-top linerboard. The precision estimates are based on 5 determinations per test result and 3 test results per lab, per sample, again in an 1800 s test.

- 9.2 Hard-sized, Printing Papers (120 s)  
Repeatability (within a lab) = 8 %  
Reproducibility (between laboratories) = 10 %

Corrugated Boxes (1800 s)  
Repeatability (within a lab) = 5.5 %  
Reproducibility (between laboratories) = 18 %

Linerboard (1800 s)  
Repeatability (within a lab) = 2.5 %  
Reproducibility (between laboratories) = 14.5 %

2002 Study of 1800 s Cobb					
	Mean	<i>r</i>	% <i>r</i>	<i>R</i>	% <i>R</i>
Kraft Linerboard	115.3	2.1	1.9%	15.0	13.0%
White top Liner	111.4	3.3	3.0%	17.3	15.6%
Corrugated Box 1	134.3	7.6	5.6%	24.9	18.5%
Corrugated Box 2 (WT)	124.7	6.4	5.1%	21.9	17.5%

Repeatability and reproducibility are estimates of the maximum difference (at 95%) which should be expected when comparing test results for materials similar to those described above under similar test conditions. These estimates may not be valid for different materials or testing conditions.

NOTE 5: Some users have noticed higher precision percentages when using smaller test areas compared to those using standard areas for similar samples.

## 10. Keywords

Blotting papers, Absorptivity, Sized papers, Sizing, Cobb tests, Paper, Paper board, Corrugated boards, Fiber boards

## 11. Additional information

11.1 Effective date of issue: To Be Assigned.

11.2 An effect of natural aging has been noticed in many papers. For example, results on cup stock papers, aged a few weeks, are usually less than on papers tested immediately after being made. [In contrast, results on some neutral-sized recycled liners, aged a few months, are sometimes greater \(more absorptive\) than on papers tested immediately after being made.](#)

11.3 The Cobb test may also be suitable with other (water base) solutions, such as dilute lactic acid and hot coffee for food board and cup stock, and possibly ink for writing and printing papers.

11.4 For specimens that have long penetration times or have surfaces that are difficult to wet, one may substitute the distilled or deionized water with water having a known concentration of wetting agent. When reporting results, also indicate the exposure time, total head, wetting agent and concentration.

11.5. Various small scale studies by different companies have shown only limited (gross) correlation between Cobb values for one time period and Cobb values for another time period. There does not appear to be a universal equation to convert between Cobb values at different time periods.

11.6 The Collaborative Testing Service (CTS) study discussed in the precision statement (9.2) involved kraft colored and white top liners, printed and unprinted surfaces, crushed flutes and uncrushed flutes, whole combined board and samples with the outside liner separated from the medium/inside liner, and the linerboard that went into producing the outside facing of the combined board tested. The study conclusions show that printed vs. unprinted and crushed flutes vs. full height corrugated resulted in no statistical difference in test results. The outside linerboard when tested alone had statistically different (lower) results in the 30-min Cobb test when compared to the various combined board samples tested. The outside linerboard samples that were split apart from the medium/inside liner closely approximated the Cobb test values of the actual liner as tested in its uncombined state. While wide variation was noted in the actual gain in  $\text{g/m}^2$  of water pickup of the combined vs. uncombined and split apart substrates, the average gain in  $\text{g/m}^2$  was between  $15 \text{ g/m}^2$  and  $20 \text{ g/m}^2$  for the 30-min Cobb test. It is assumed that additional water was absorbed by the corrugating medium, but the transmission mechanism is not understood. Thus, splitting apart the board is not recommended when evaluating the Cobb performance of combined board.

11.7 This method has been revised multiple times since its development in the early 1940s. Some highlights of those revisions follow.

11.7.1 The 1969 revision incorporated standardization of the test area at  $100 \text{ cm}^2$  ( $15.5 \text{ in.}^2$ ) and the pressure head depth at  $1.0 \pm 0.1 \text{ cm}$  ( $0.39 \pm 0.04 \text{ in.}$ ), standardization of the blotting method with specification of the blotters and rollers used, and specification of the water as distilled or demineralized.

11.7.2 The 1990 revision made mention of the use of alternate clamping mechanisms.

11.7.3 In the first few years of the 21st century an attempt was made to separate the method into two related methods, one for papers and another for corrugated board. Those explorations lead to some of the expanded precision information cited above. In the end it was decided to re-unify the method, resulting in the 2004 revision with more explicit information about the applicability of this method to corrugated board.

11.7.4 The 2009 revision included many editorial changes necessitated by the explicit incorporation of corrugated board to the 2004 revision, rationalizing information that previously was included as "additional information." The information in the appendix was moved to more appropriate locations in the text. As well, the method now explicitly incorporates information on other ring sizes in use across the industry.

11.7.5 The 2019 and 2024 revisions included minor editorial and clarifying corrections and a review of related methods listed (many of which were then removed.)

11.8 Related methods: ASTM D 3285 (withdrawn), Canadian PAPTAC F.2 (historical); Australian AS/NZ 1301.411s; Scandinavian SCAN P-12 (withdrawn); ISO Standard 535.

## References

1. Cobb, R. M., and Lowe, D.V., "A Sizing Test and Sizing Theory," *Tech. Assoc. Papers* **17**: 213 (1934); *Paper Trade J.* **98** (12): 43 (1934).
2. Cobb, R.M., "What I Do Not Know About Sizing and Capillary Flow," *Tech. Assoc. Papers* **18**: 209 (1935); *Paper Trade J.* **100** (16): 42 (1935).
3. Egy, W.L., "The Cobb Sizing Test," *Pulp Paper Mag. Can.* **38** (7): 499 (1937).
4. Codwise, P.W., "Water Resistance of Paper," *Tech. Assoc. Papers* **19**: 231 (1936); *Paper Trade J.* **102** (3): 39 (1936).

Your comments and suggestions on this procedure are earnestly requested and should be sent to the TAPPI Standards Department.



Deleted: .